

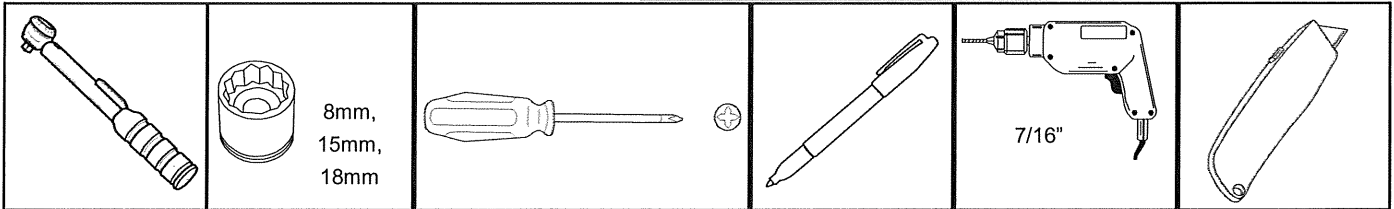

# FRONT BUMPER

1X	A	2X	B	12X	D	2X	F
		4X	C	2X	E	2X	G



\*NOTE: VEHICLES WITH FOG LAMPS MUST DISCONNECT AND SECURE WIRE HARNESS TO VEHICLE USING TIE WRAPS OR ELECTRICAL TAPE, NOT INCLUDED IN KIT.

\*NOTE: SAVE OEM BUMPER ASSEMBLY AND FASTENERS FOR RE-INSTALLATION.

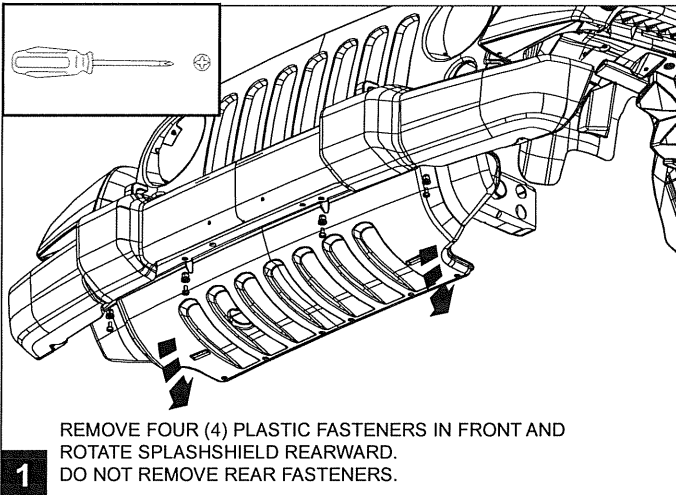

**1** REMOVE FOUR (4) PLASTIC FASTENERS IN FRONT AND ROTATE SPLASHSHIELD REARWARD. DO NOT REMOVE REAR FASTENERS.

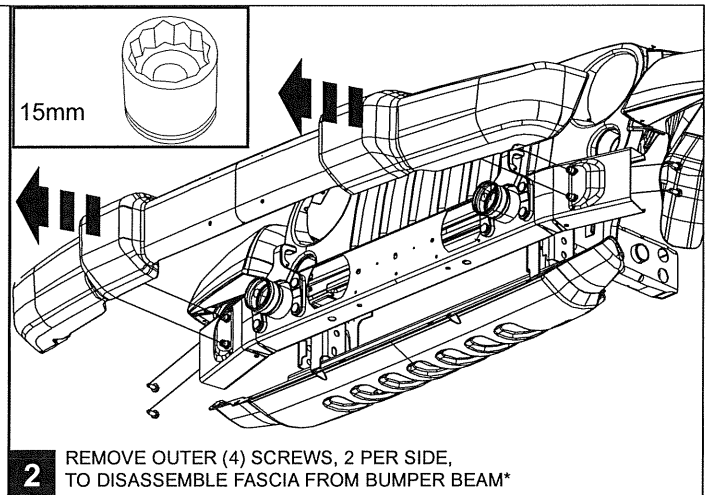

**2** REMOVE OUTER (4) SCREWS, 2 PER SIDE, TO DISASSEMBLE FASCIA FROM BUMPER BEAM\*

SPLASHSHIELD TO BE MODIFIED FOR INSTALLATION OF TUBULAR FRONT BUMPER

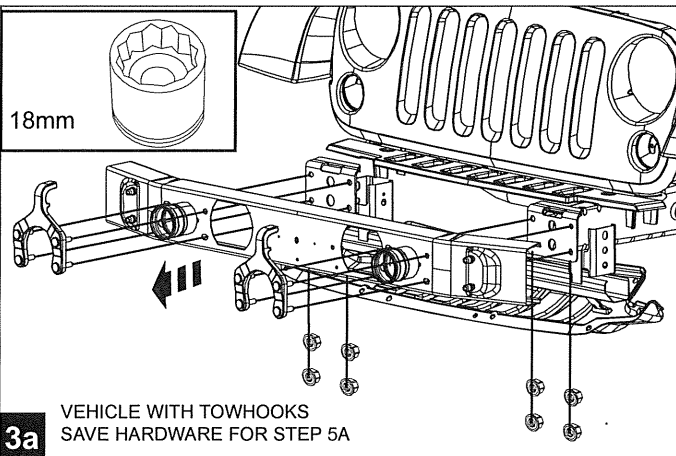

**3a** VEHICLE WITH TOWHOOKS  
SAVE HARDWARE FOR STEP 5A

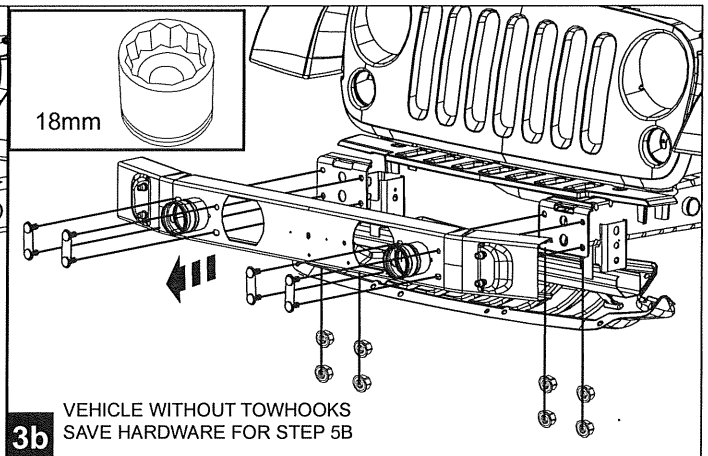

**3b** VEHICLE WITHOUT TOWHOOKS  
SAVE HARDWARE FOR STEP 5B



MOPAR.

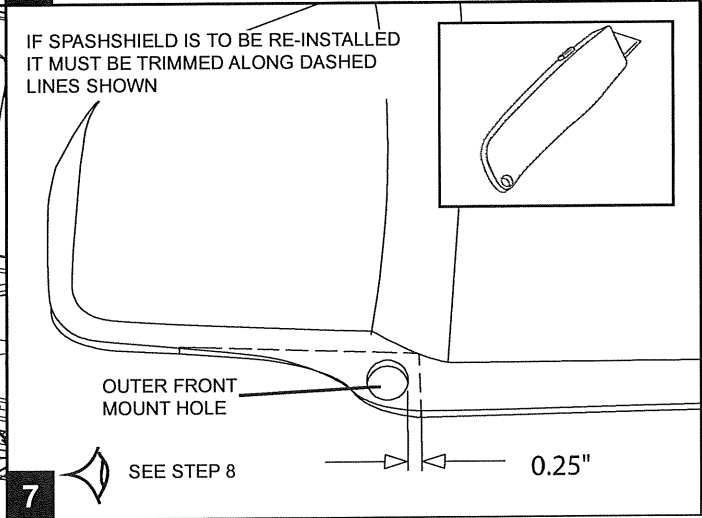
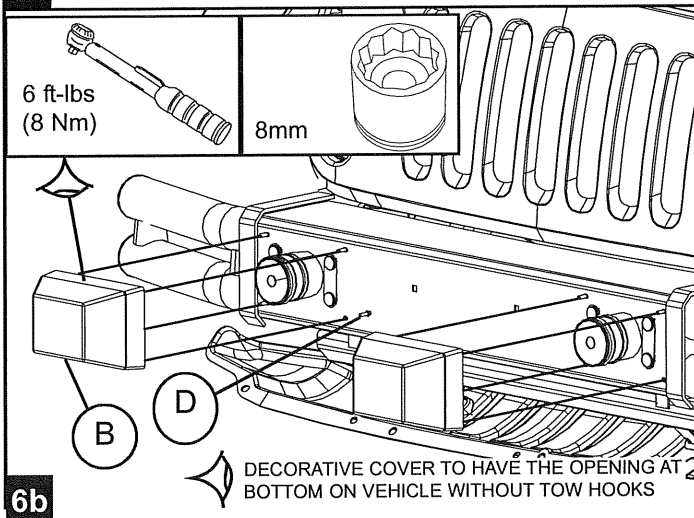
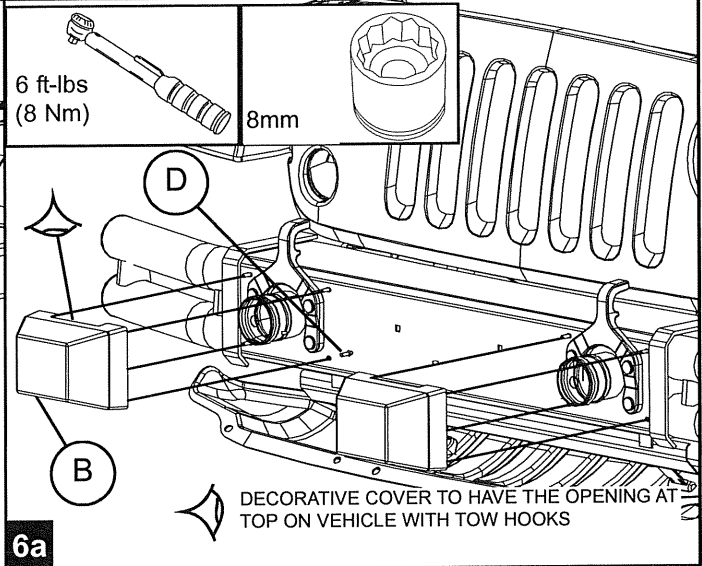
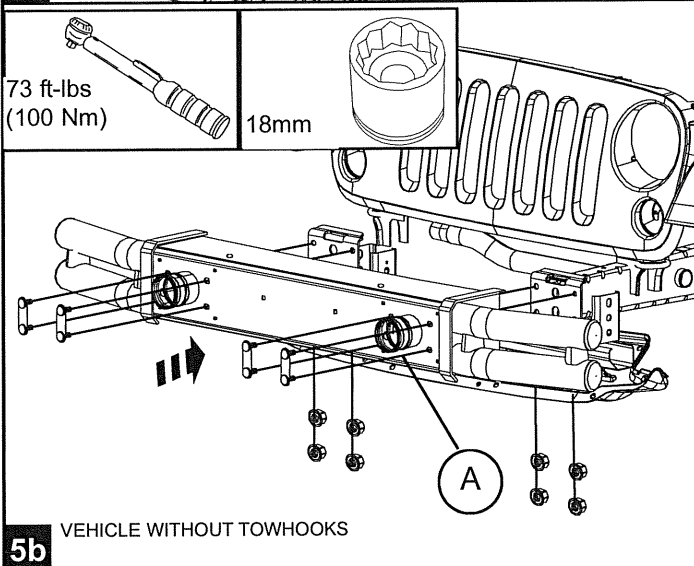
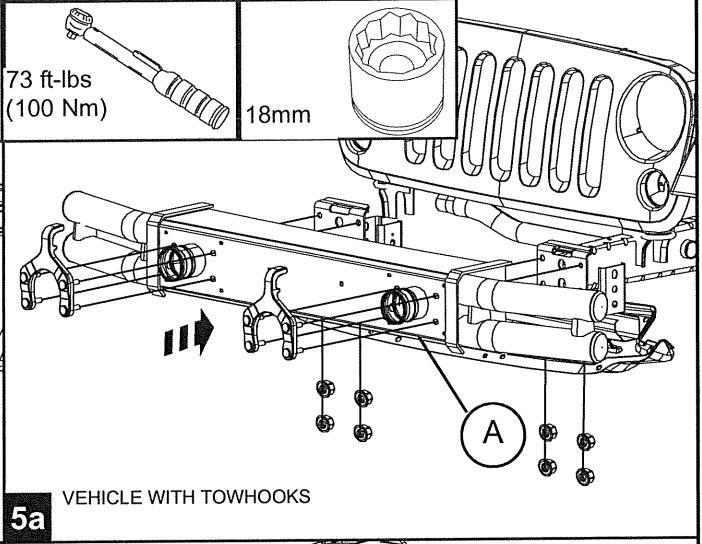
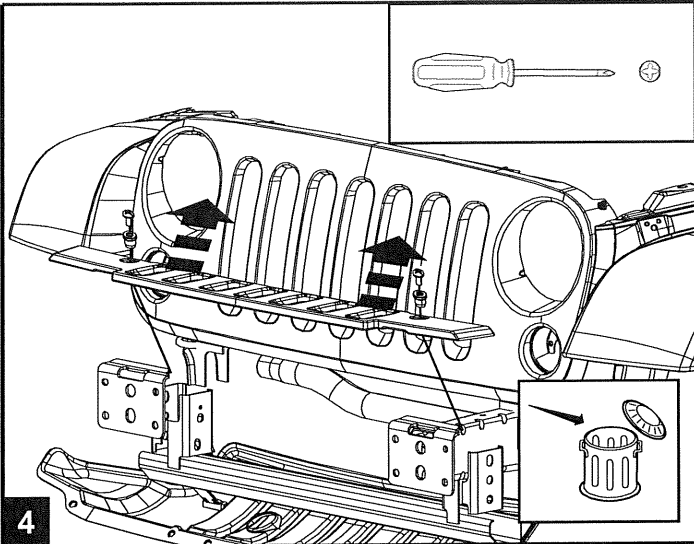



SEE STEP 7

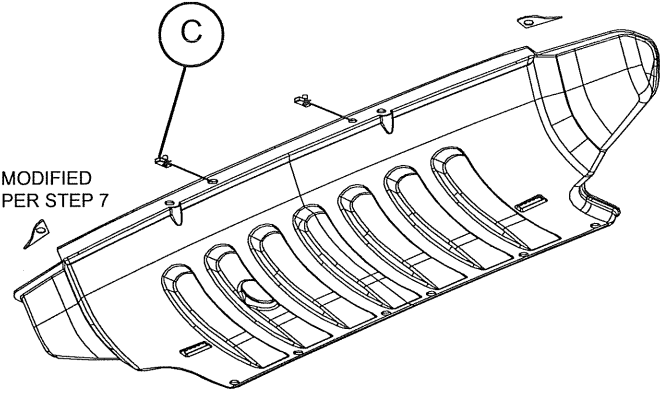

8 INSTALL TWO (2) U-NUTS

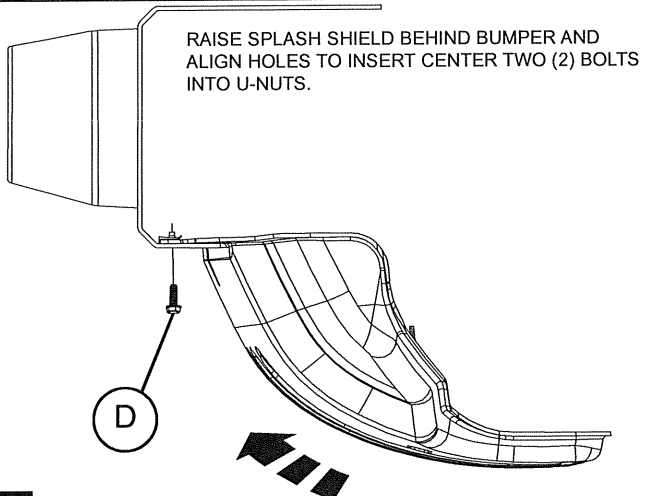

RAISE SPLASH SHIELD BEHIND BUMPER AND ALIGN HOLES TO INSERT CENTER TWO (2) BOLTS INTO U-NUTS.

9

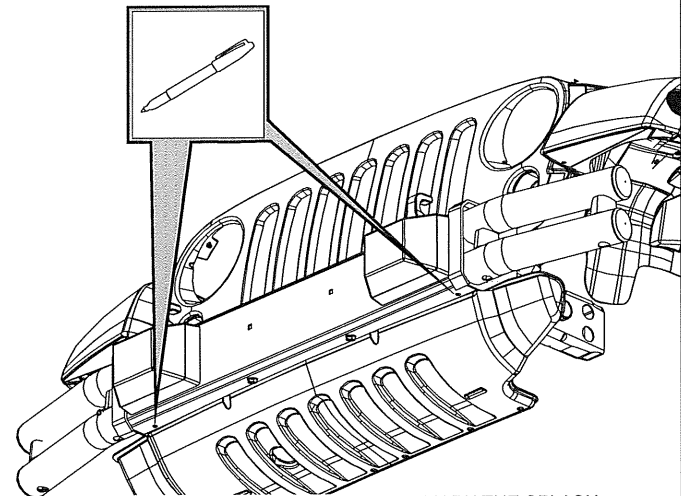

10 USE HOLES IN BUMPER AS A TEMPLATE. MARK THE SPLASH SHIELD TO LOCATE OUTER HOLES. REMOVE SPLASH SHIELD AND DRILL 7/16" DIAMETER HOLES.

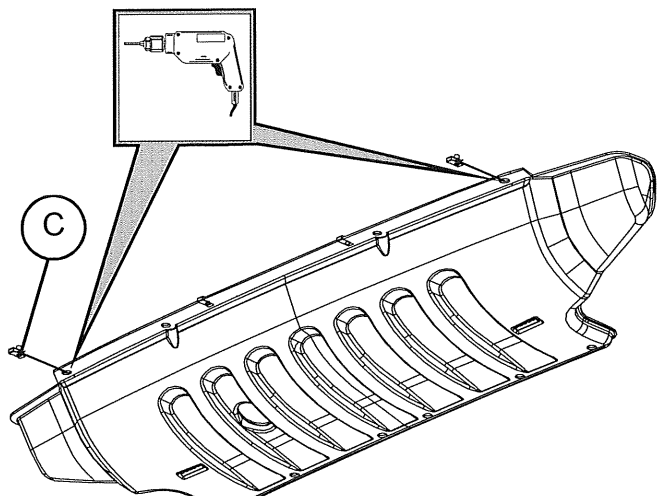

11 DO NOT DRILL THROUGH BUMPER. INSTALL TWO (2) U-NUTS.

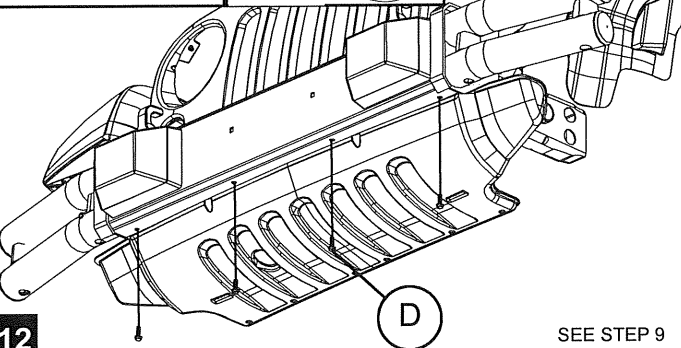
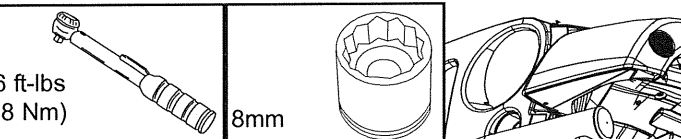

12 SEE STEP 9

SPLASH SHIELD MAY BE TRIMMED MANY WAYS, IT IS UP TO CUSTOMERS DISCRETION FOR DESIRED APPEARANCE.  
 FOG LAMP REPLACEMENT:  
 FASCIA WITH FOG LAMPS USE MOPAR PART NUMBER 82209880 (FOG LAMPS KIT) AND 82210549 (WIRING HARNESS KIT).  
 FASCIA WITHOUT FOG LAMPS USE PART NUMBER 82210217 (FOG LAMP KIT COMPLETE)  
 PLUG HOLES WITH ITEM "E" FOR NO INSTALLATION OF FOG LAMPS  
 ROUND HOLES IN BUMPER FACE ARE PROVIDED TO INSTALL LICENSE PLATE USING INCLUDED HARDWARE (ITEMS G & F).

